



tubra[®] - PGM DN 25/32

Pump group for mixed heating circuits

Assembly and operating instructions

Content

- 1 Introduction..... 3
 - 1.1 Intended purpose..... 3
 - 1.2 Safety information..... 3
 - 1.3 Other applicable documents 3
 - 1.4 Delivery and transport..... 3
- 2 Layout – scope of delivery..... 4
- 3 Technical specifications..... 5
 - 3.1 General instructions..... 5
 - 3.2 Dimensions / required space..... 6
 - 3.3 Pressure loss..... 7
- 4 Assembly..... 8
 - 4.1 General..... 8
 - 4.2 Wall mounting..... 8
 - 4.3 Mounting sensor 9
 - 4.4 Servo motor of the mixing device.....10
 - 4.5 Progressive curve / mixer behavior11
 - 4.6 Hydraulic Connection.....12
 - 4.7 Electrical connection.....12
 - 4.8 Modification from flow on the left to flow on the right.....14
- 5 Operation..... 16
 - 5.1 Circulation pump.....16
 - 5.2 Gravity brake16
- 6 Start-up..... 16
 - 6.1 Leak testing and filling the system16
 - 6.2 Commissioning the circulation pump.....16
- 7 Maintenance/service..... 17
 - 7.1 Pump replacement.....17



1 Introduction

This manual describes the assembly, operation and maintenance of the **tubra®-PGM DN 25/32** heating circuit station.

Please read through these instructions carefully before starting installation.

Non-compliance will invalidate all claims under the guarantee and warranty.

This manual is intended for trained specialists with an adequate level of expertise in handling heating systems, water pipe installations and electrical installations.

The installation and commissioning procedures should only be conducted by qualified, specialist personnel.

The **tubra®-PGM DN 25/32** pump group must only be installed and operated in a dry environment that is protected from frost.

Illustrations are symbolic and may differ from product to product.

Subject to technical changes and errors.

1.1 Intended purpose

The **tubra®-PGM DN 25/32** pump group serves exclusively to mix and circulate the heating water for operating a heating circuit. The pump group must only be operated in conjunction with the media listed in the technical data.

Any improper use or modifications to the assembly, structure or components can prevent safe operation of the system and result in the exclusion of all claims under the warranty and guarantee.

1.2 Safety information

In addition to country-specific guidelines and local directives, the following technical regulations must also be taken into account:

- EN 12 828 Heating systems in buildings
- DIN 4753 Water heaters, water heating installations and storage water heaters for drinking water
- DIN 18 380 Heating systems and central water heating systems
- DIN 18 381 VOB: Gas-, water-, sewage installation works
- DIN 18 421 VOB: thermal insulation work on thermal installations
- VDI 2035 Avoidance of damage in hot water heating systems
- VDE 0100 Series of standards on the use of electrical equipment of machines
- VDE 0701 Repair, modification and testing of electric equipment
- VDE 0190 Main equipotential bonding of electric facilities
- BGV Accident prevention regulations of workers' compensation associations



As the system can reach temperatures $> 60\text{ °C}$, there is a risk of scalding and burning through contact with the components.

1.3 Other applicable documents

Also observe the assembly and operating instructions for the various components used, such as the servo motors.

1.4 Delivery and transport

Please check to ensure the product is complete and undamaged immediately after receipt. Any damage or complaints must be reported immediately.

2 Layout – scope of delivery

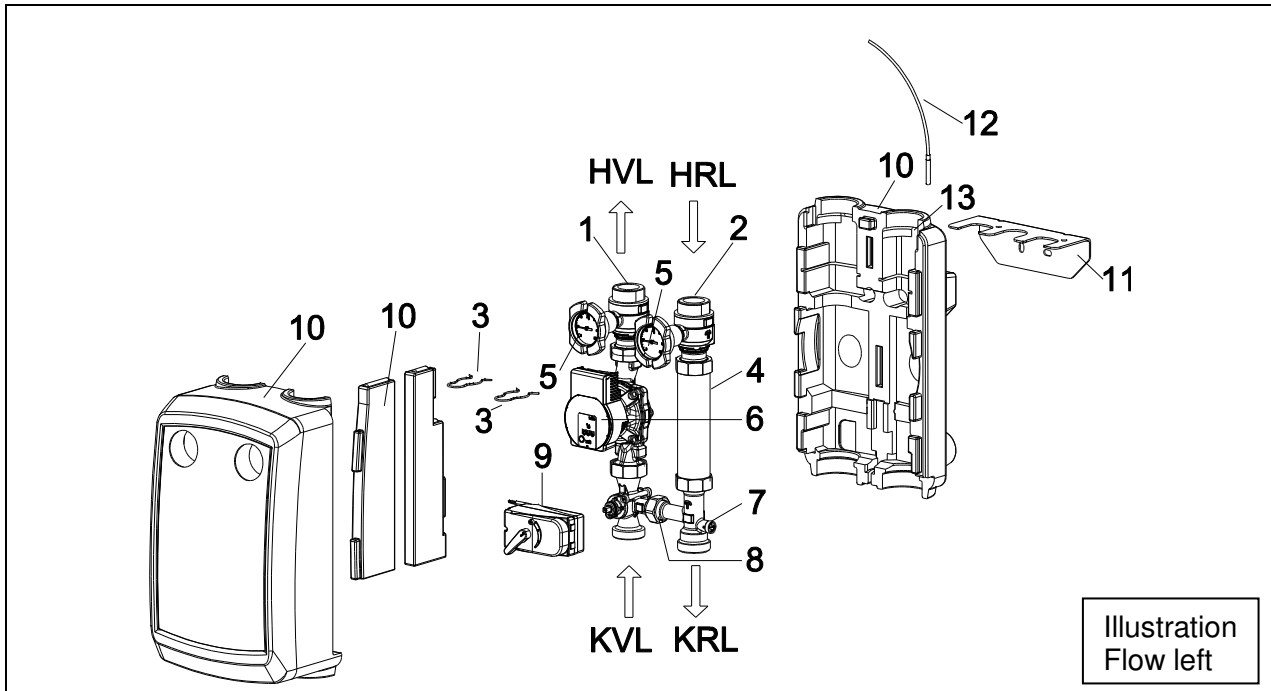

Pos.	Designation	ET- Number	
1	Ball valve for heating flow (HVL), with applying prism for temperature sensor	968.50.58.00.01	
2	Ball valve for heating return (HRL), with applying prism for temperature sensor	968.50.57.00.01	
3	Safety springs		
4	Adapter pipe		
5	Dial thermometer (flow/retrun)	665.24.25.00	
6	Wilo Para 25/6 Wilo Para 25/8 Grundfos UPM3 25-70 Auto Grundfos Magna3 25-6 Grundfos Magna3 25-8	180.25.02.00.01 180.25.83.00.01 180.25.71.00.01 on request on request	
7	Gravity brake spindle DN 25 Gravity brake spindle DN 32	949.25.11.00.01 949.32.11.00.01	
8	Mixer DN 25 flow left / flow right Mixer DN 32 flow left / flow right	949.25.20.00 / 949.25.10.00 949.32.20.00 / 949.32.10.00	
9	Servo-motor 230 V Servo-motor 0-10 V	649.20.68.00.01 649.20.78.00.01	
10	Insulation consisting of front and rear shell, cover and inserts	968.50.09.00.01	
11	Mounting angle		
12	Flow sensor [not included in scope of delivery]		
13	Recess for the flow sensor		
()	Replacement spindle ball valve	968.00.06.00.01	
()	Cooling accessory set DN 25/DN32	968.10.25.00	
()	Gasket set 4 pcs. f. G 1½	660.00.04.00.01	
HVL	Heating flow	KVL	Boiler flow
HRL	Heating return	KRL	Boiler return



3 Technical specifications

3.1 General instructions

Designation/type		tubra® -PGM	tubra® -PGM
Nominal size		DN 25	DN 32
Nomina output ΔT 10 K (20 K), k_{vs} Mischer		k_{vs} 4 up to 8 m ³ /h Output: depending on pump type up to 50 kW (100kW)	k_{vs} 6 bis 12 m ³ /h Output: depending on pump type up to 75 kW (150 kW)
Connections	On the heating circuit	G1½ AG / Rp 1"	G1½ AG / Rp 1"
	On the boiler	G1½ AG	G2 AG
Max. operating pressure		3 bar	3 bar
Max. operating temperature		95 °C	95 °C
Medium		Heating water according to VDI 2035	Heating water according to VDI 2035
Opening pressure on the gravity brake		20 mbar	20 mbar
Circulation pump		Wilo Para RS 25/6 SC	Wilo Para RS 25/8 SC
	optional	Wilo Para RS 25/8 SC	
	optional	Grundfos UPM3 25-70 AUTO / Hybrid	Grundfos UPM3 25-70 AUTO / Hybrid
	optional	without pump	without pump
	On demand	Other pumps (see pressure loss curve)	
Electrical connection		230 V AC/ 50-60 Hz	230 V AC/ 50-60 Hz
Mixing device with servo motor			
Mixer time / rotation angle		110 s / 90°	110 s / 90°
Permitted ambient temperature		0-55°C	0-55°C
Electrical connection		230 V AC/ 50-60 Hz	230 V AC/ 50-60 Hz
Power draw		1m cable	1m cable
Input	Operational	5 W	5 W
	Standby	0 W	0 W
Housing protection type/protection class		IP 44 IEC 529	IP 44 IEC 529
Protection class		II VDE 0631	II VDE 0631



3.2 Dimensions / required space

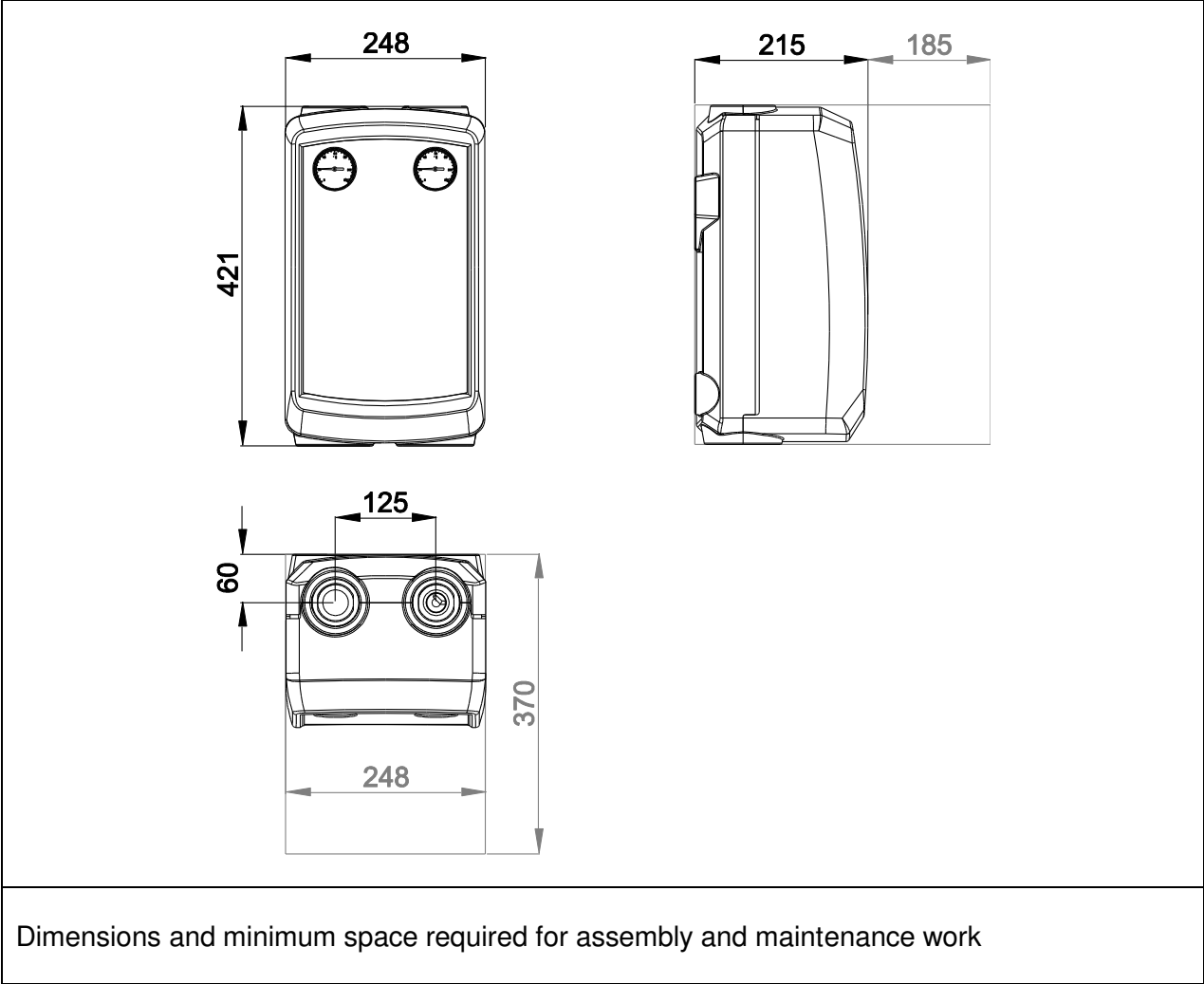

Dimensions and minimum space required for assembly and maintenance work



3.3 Pressure loss

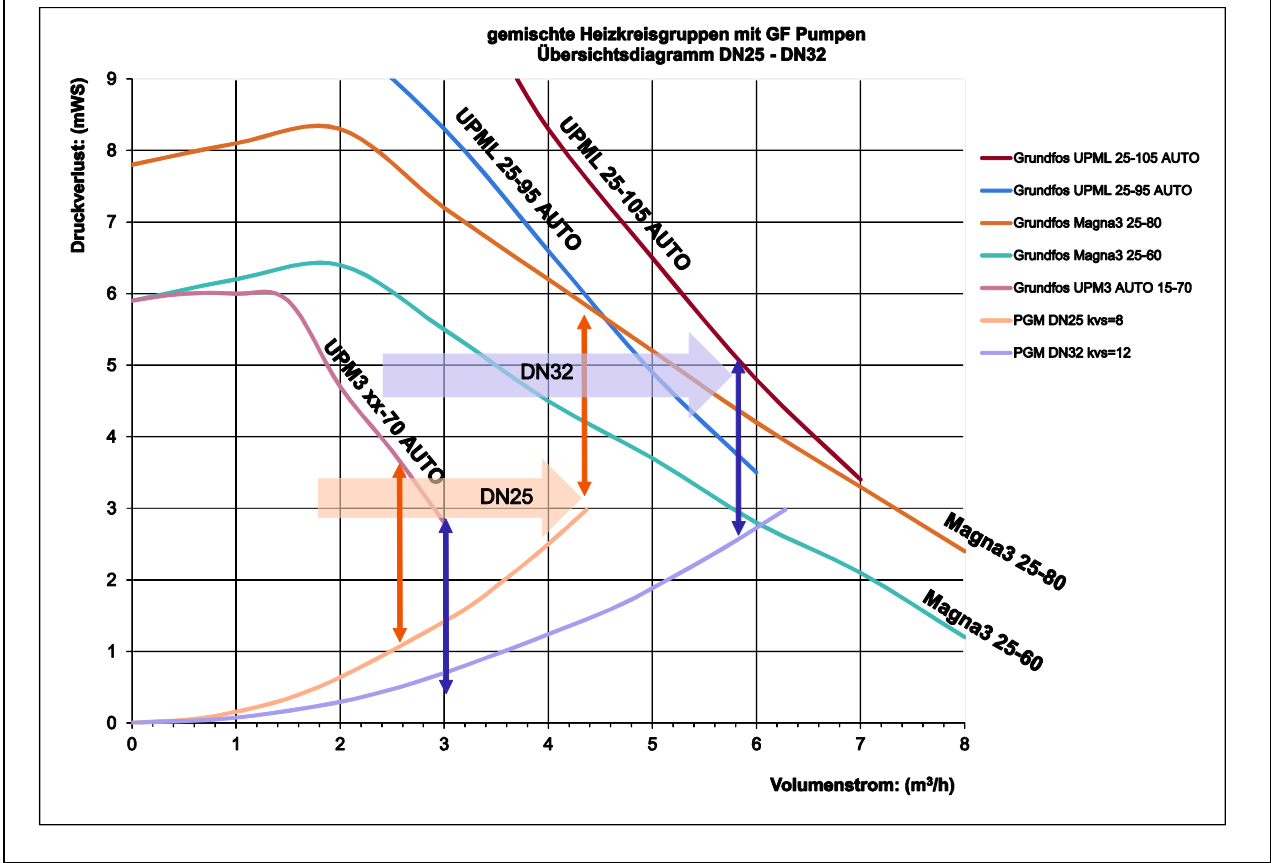
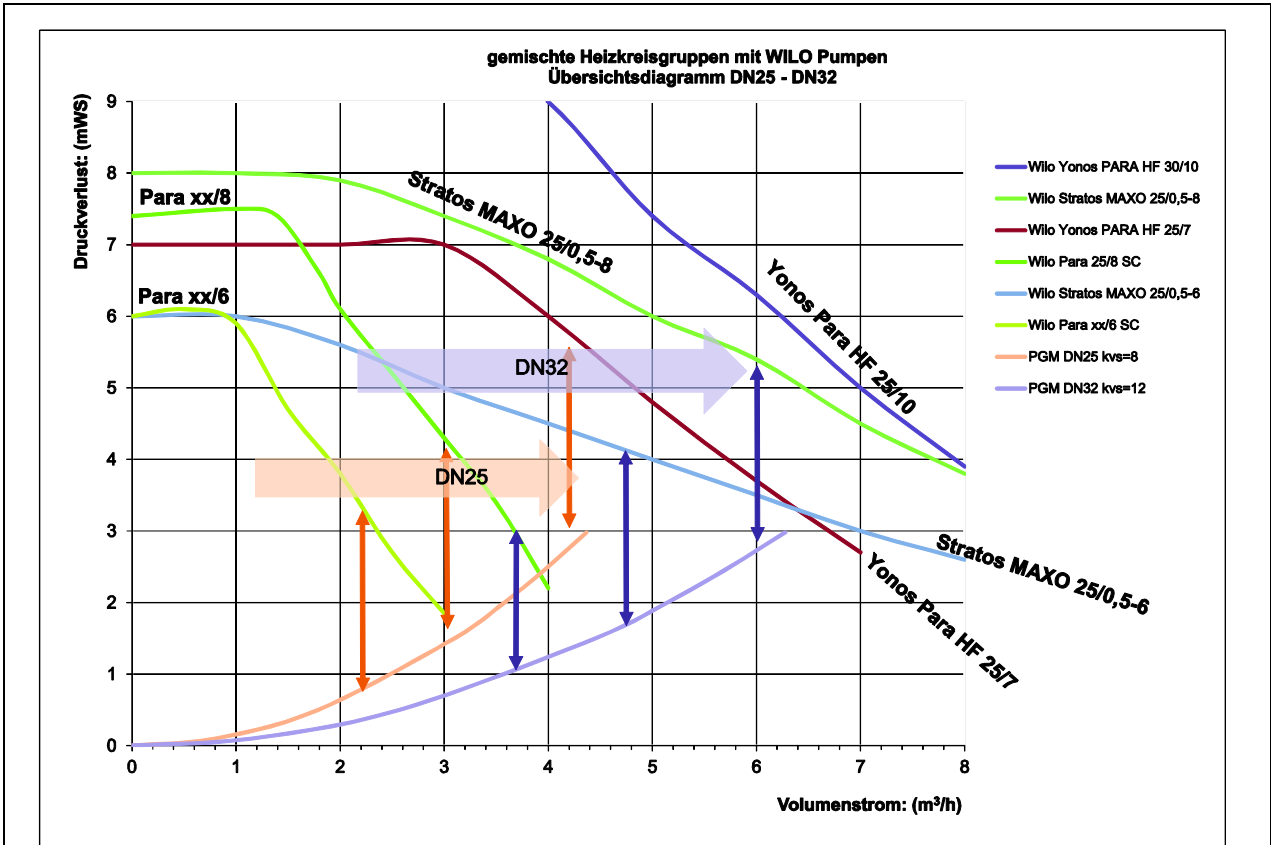

4 Assembly

4.1 General

The heating circuit station can be installed and operated in many different installation positions, provided that the pump shaft is horizontal.

4.2 Wall mounting

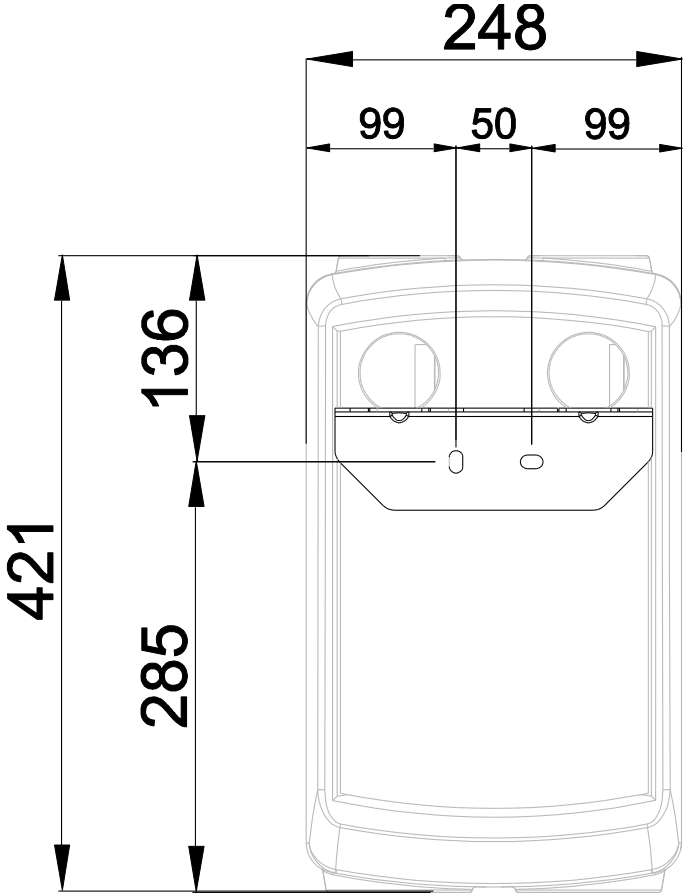
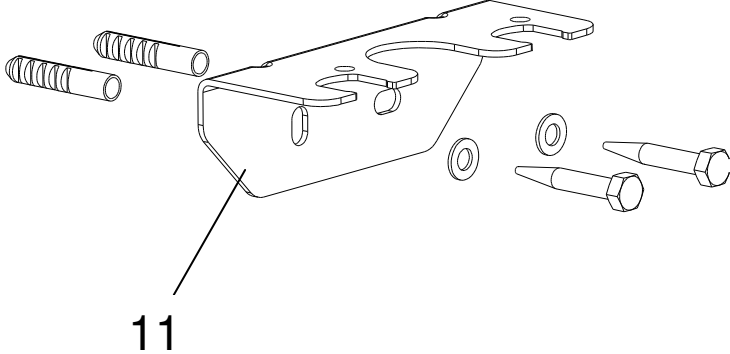
	<p>Remove securing springs [3]. Lift the feed and return lines and remove them from the Pull out angle [11]. Remove the rear insulation shell.</p> <p>Mark attachment points of the mounting bracket [11] to the wall and drill two $\varnothing 10$ mm holes.</p>
 <p>11</p>	<p>Place the dowel and tighten the mounting bracket [11] with the screws and washers.</p> <p>Align mounting bracket [11] horizontally.</p> <p>Slide the rear insulation shell onto the mounting bracket [11].</p> <p>Insert the feed and return line in the mounting bracket and secure with the locking springs [3].</p>

4.3 Mounting sensor

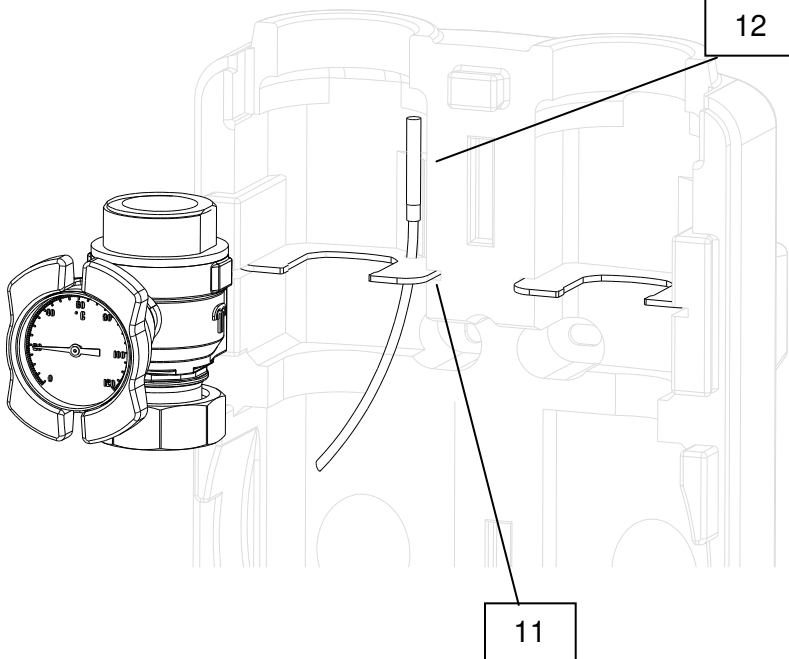
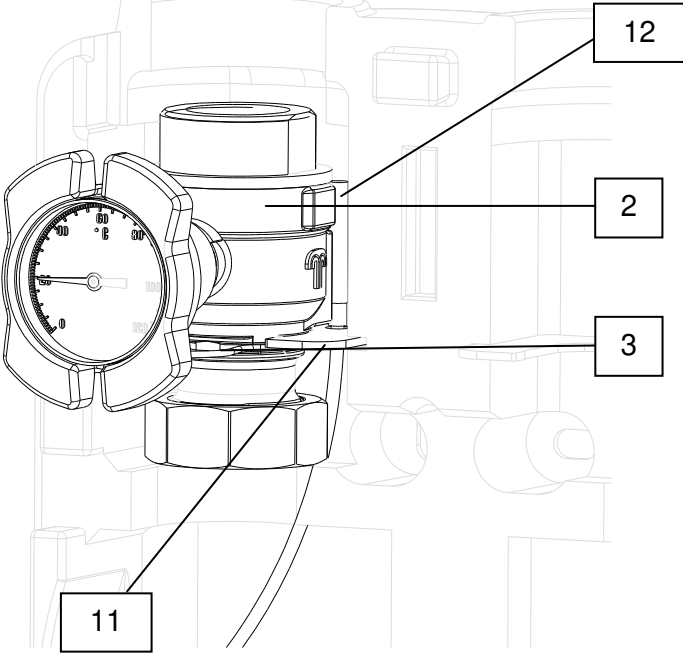
	<p>The sensor [12] is inserted into the hole provided in the mounting bracket [14] from below.</p>
	<p>Mount pump group and secure ball valves [2] with safety spring [3].</p> <p>Fasten sensor [12] and cable with cable tie.</p>

4.4 Servo motor of the mixing device

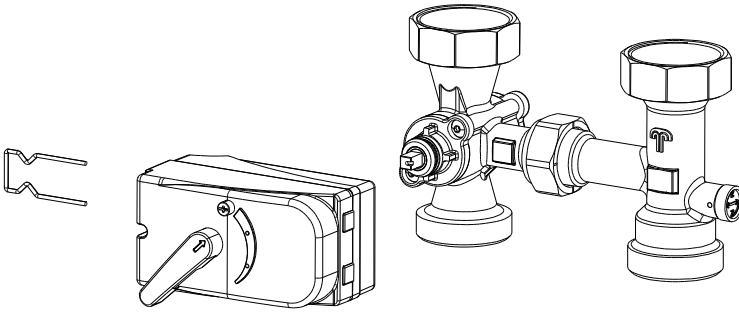
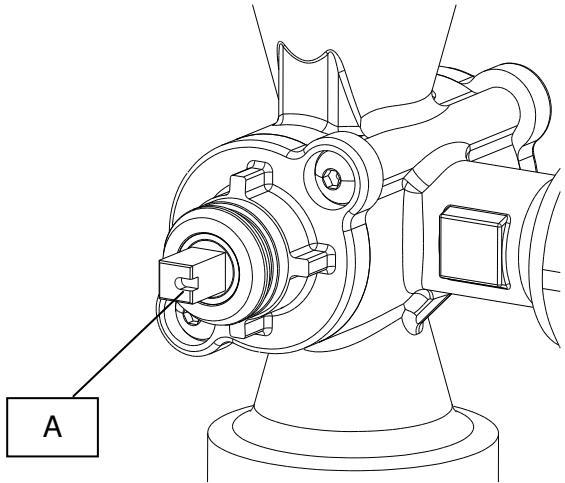
Mount servo motor on valve	
	<p>!</p> <p>Work on the electrical system as well as the opening of electronic housings may only be carried out in a voltage-free state and only by authorized specialist personnel.</p> <p>To remove the servomotor, the clip must be pulled out of the servomotor.</p> <p>Then the servomotor can be removed from the valve.</p>
	<p>Attention</p> <p>When assembling the servomotor, the actuating handle of the actuator must be in the maximum position and the notch of the driver [A] must be left at 3 o'clock on the left and 9 o'clock on the right in the pre-run.</p> <p>Before mounting, the clip must be positioned in the servomotor. Then place the servomotor on the valve and press down.</p> <p>Insert clip to fix the servomotor.</p>

4.5 Progressive curve / mixer behavior

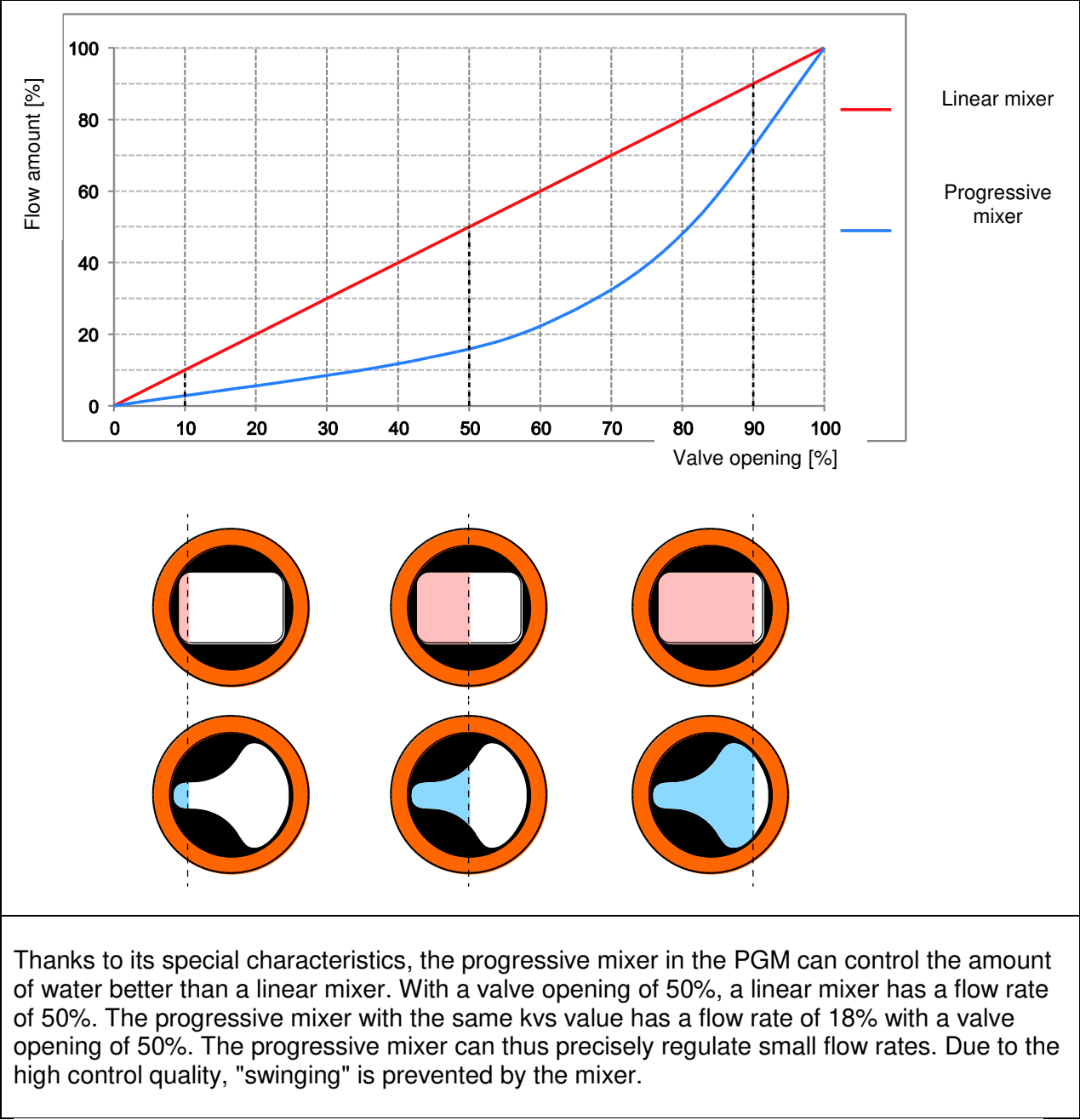

4.6 Hydraulic Connection

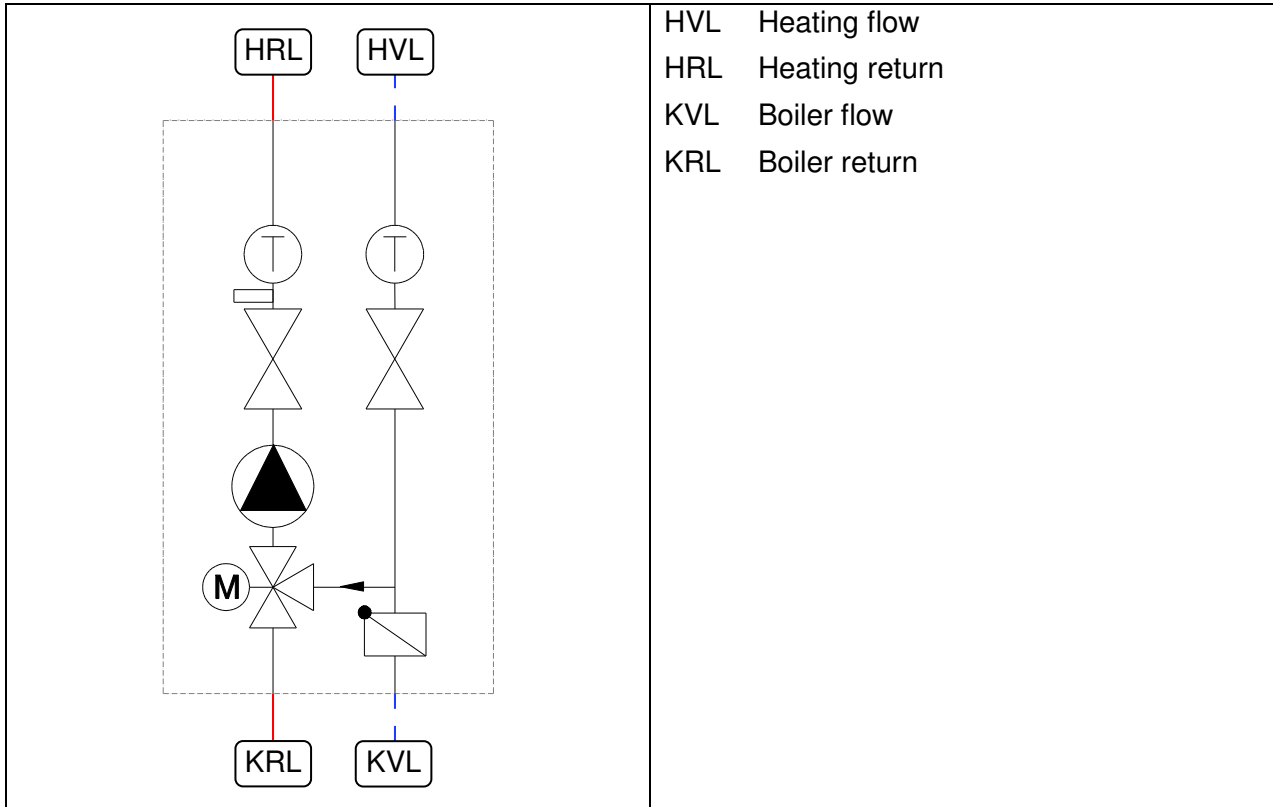

This is a sample illustration which does not claim to be exhaustive; it does not replace specialist planning.

4.7 Electrical connection

4.7.1 General instructions

Only authorised, specialist personnel are permitted to open electrical housings and work on the electrical system after de-energising the equipment.
When establishing connections, make sure the terminal assignments and polarity are correct.
Protect the electrical components from overvoltage.



Danger!

Risk of fatal electric shock as a result of incorrect electrical connections.

- Electrical connections must exclusively be created by electricians approved by energy suppliers and as per the locally applicable regulations.
- Disconnect the supply voltage prior to conducting any work.

4.7.2 Circulation pump

Observe the operating manual of the circulation pump.



4.7.3 Servo motor mixer with cable

Terminal assignment of mixer servomotor							
	L [black] Control input for anticlockwise rotation (CCW)						
	N [blue] Neutral conductor N						
	L [brown] Control input for clockwise rotation (CW)						
Terminal assignment of mixer servomotor 24 V							
	<table border="1"> <tr> <td>DIP</td> <td>CCW ↺</td> <td>CW ↻</td> </tr> <tr> <td>1</td> <td>OFF</td> <td>ON</td> </tr> </table>	DIP	CCW ↺	CW ↻	1	OFF	ON
DIP	CCW ↺	CW ↻					
1	OFF	ON					
Function							
<p>Position: „max“ = max.feed temperature</p>	<p>Position: „min“</p> <p><i>Voltage at black cable:</i> The drives moves counterclockwise from the "max" position to the "min" position</p> <p><i>No control voltage:</i> Actuator and valve remain in their respective positions</p> <p><i>Voltage at brown cable:</i> The drives moves clockwise from the "min" position to the "max" position</p> <p>A limit switch is actuated in the end positions which switches off the motor.</p>						
Manual adjustment							
	<p>Manual adjustment: Use a screwdriver to press down the locking button and turn it 90°. Turn the handle to the desired position.</p>						

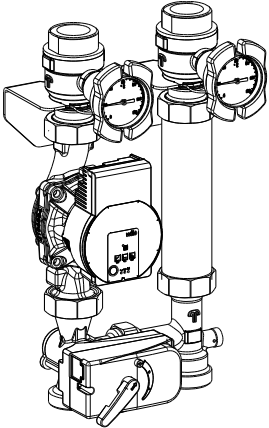
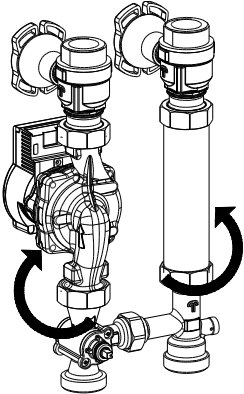
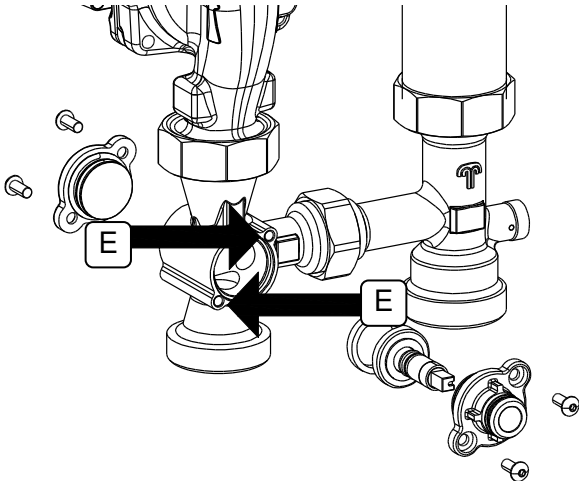

4.8 Modification from flow on the left to flow on the right

	<p>Loosen union nut.</p>
	<p>Turn both flow and return line backwards.</p>
	<p>Disassemble actuator [9].</p> <p>Remove the front and rear covers from the rotary valve. Take out the rotary valve and reassemble it from the front. Replace both caps. Notch of the rotary valve is at 9 o'clock. (see 4.4)</p> <p>Fixing screws [E] with hexagon socket</p>

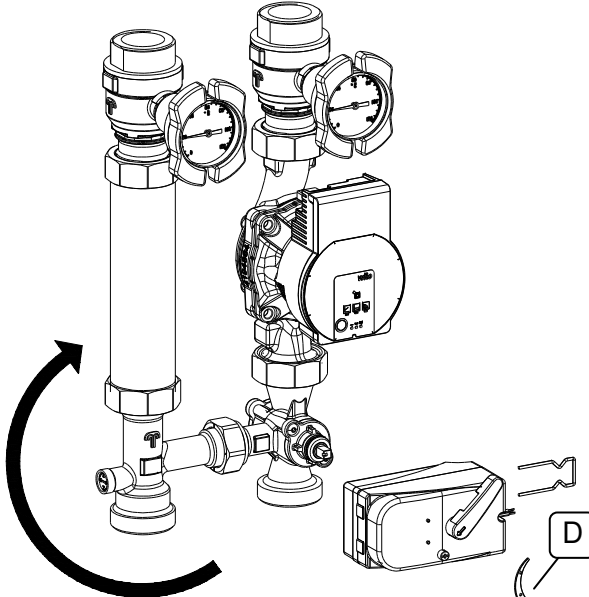
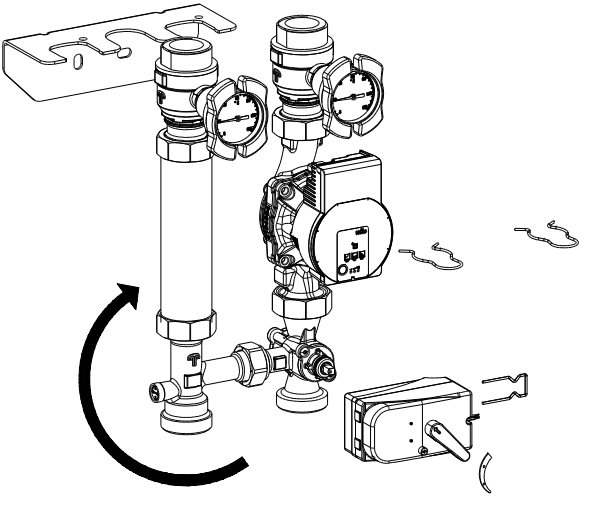
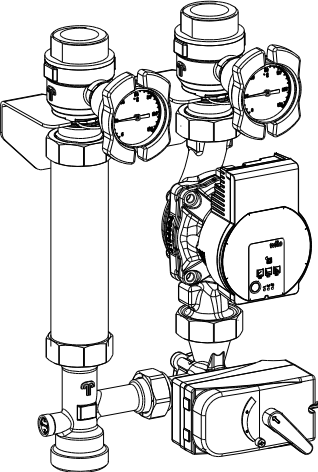
	<p>Turn whole pump group. The flow line is now on the right, the pump is facing forwards.</p> <p>Tighten all the union nuts.</p> <p>Remove directional arrow [D], rotate through 180° and remount. Turn servo-motor to the new "max" position.</p>
	<p>Place servomotor [9] with mounted clip on the mixer.</p> <p>Hook the module back into the mounting bracket and secure it with the safety springs.</p>
	<p>The pump group has now been modified from flow on the left to flow on the right.</p> <p>Note the changed direction of rotation of the servo motor.</p>

5 Operation

5.1 Circulation pump

Observe the operating manual of the circulation pump.

5.2 Gravity brake

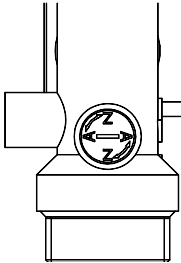
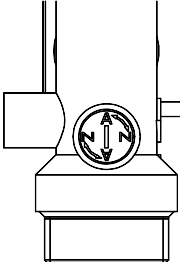
 <p>Operating position</p>	 <p>Maintenance position</p>	<p>The gravity brake [9] is put into operation in a diagonal position.</p> <p>The gravity brake can be vented for service and maintenance work.</p> <p>To vent the gravity brake, turn the adjusting screw to the flow direction.</p> <p>When the service work is complete, turn all the adjusting screws back to the operating position.</p>
---	---	---

6 Start-up

Complete installation of all hydraulic and electrical components is a precondition for commissioning.

Turn all ball valves and gravity brakes to the operating position for commissioning.

6.1 Leak testing and filling the system

Check all of the system components, including all of the factory-fitted elements and stations, to ensure they are leak-tight; repair any detected faults accordingly. When doing so, adapt the test pressure and test duration to match the respective piping system and the respective operating pressure.

Only fill the heating system with filtered, treated water as per VDI 2035 and completely bleed the system.

6.2 Commissioning the circulation pump

Observe the operating manual of the circulation pump.

7 Maintenance/service

The manufacturer recommends having the system serviced annually by authorised, specialist personnel.

Steps to perform maintenance:

Kontrollen	Maßnahmen
1. Control of the pump	Adjust if necessary, hydraulic adjustment
2. Actuation of all ball valves	
3. Control system pressure	If necessary adjust system pressure
4. Check water quality according to VDI 2035.	Take necessary measures if necessary.

7.1 Pump replacement

The pump can be completely shut off, it can be changed without the water of the heating circuit having to be completely drained.

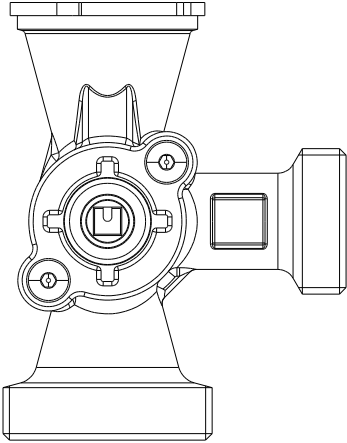
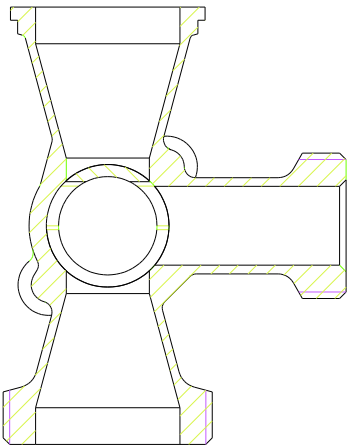
	<p>Shut off the ball valves in the supply and return lines. Separate the expansion vessel from the system and depressurise it.</p> <p>Pull the servo motor off the mixer.</p> <p>Turn the rotary valve of the mixer so that the marking point points upwards. Position 12 o'clock.</p>
	<p>The mixer is now sealed, drip tight.</p> <p>Pump replacement</p> <p>Turn the rotary slide through 180° back to the operating position, marking point at top, and open the ball valves.</p> <p>Fill and bleed the heating system to the required operating pressure.</p>

Reseller

KAPOTHERM

www.kapotherm.ro
office@kapotherm.ro
+40 0727 338 647



Gebr. Tuxhorn GmbH & Co. KG • Senner Straße 171 • 33659 Bielefeld
Tel.: +49 (0) 521 44 808-0 • Fax: +49 (0) 521 44 808-44 • www.tuxhorn.de